

MIETZSCH

GmbH Lufttechnik Dresden

USER INFORMATION

SOUND INSULATION

SOUND SILENCERS/ATTENUATORS

SOUNDPROOFING ENCLOSURES

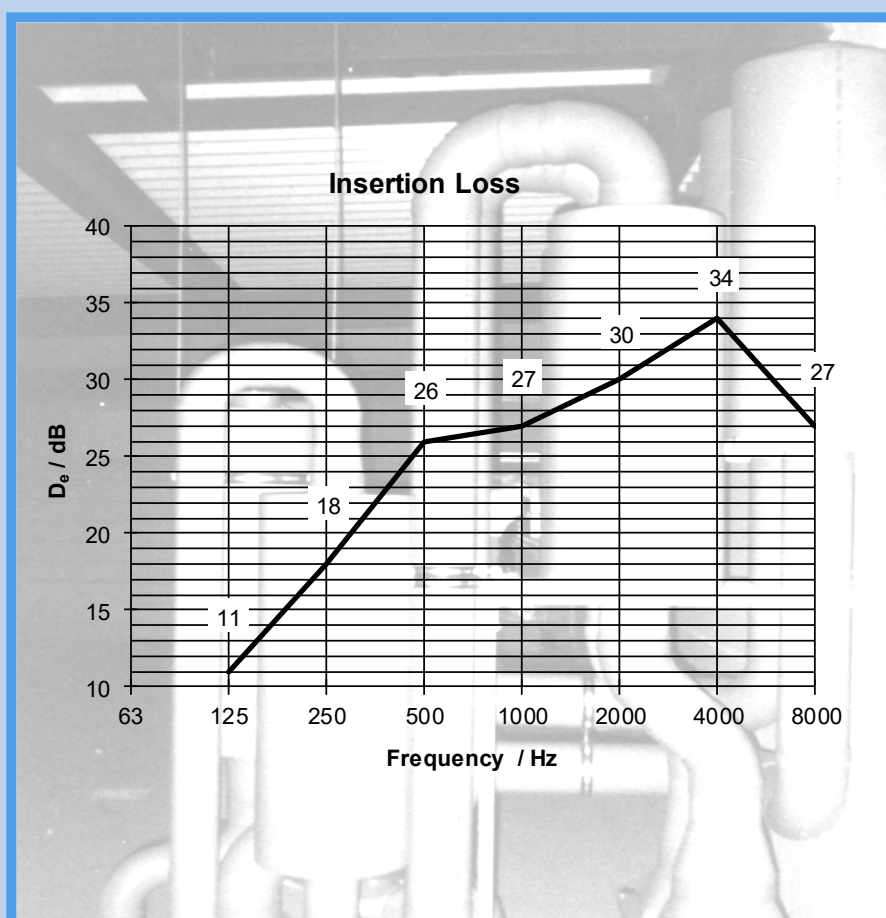

Sound insulation

KRS series ducted silencers

KRS-K series ducted silencers with core

KKS series splitter attenuators

Soundproofing enclosures for radial fans **VRE** and duct fans **VRK**

Sound insulation bases for roof fans

(see user information for **VRR** series roof fans
and user information for **VRV** series roof fans)

Use of plastic materials for high resistance to chemicals

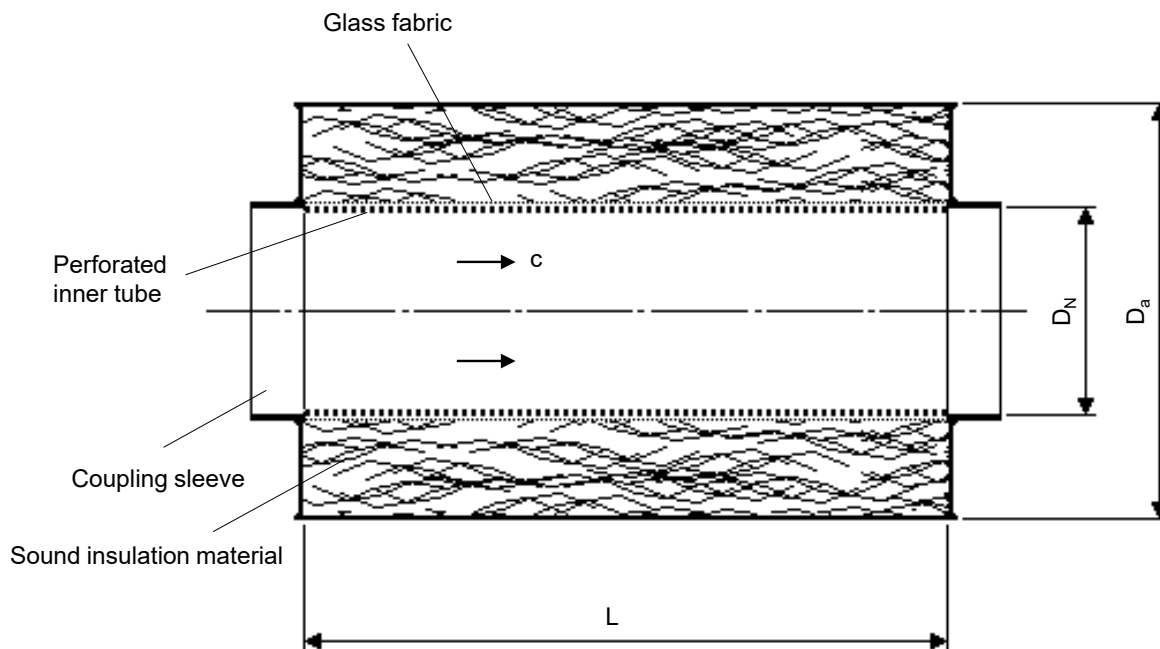

APPLICATION

The KRS series plastic ducted silencers were specifically developed for cost effective and efficient sound insulation in air conditioning and ventilation systems. The use of plastics makes them particularly suitable for applications involving aggressive media.

TYPE SERIES and DESIGN

The ducted silencers are manufactured in nominal diameters of $DN = 110 \dots 500$ mm and length of $L = 500, 1000, 1500$ and 2000 mm. The coupling sleeves are fitted at both connection ends. Special versions with welded flanges are available.

The basic body is optionally made from PVC or PPs (other materials available on request). The sound insulation material is non-flammable in compliance with DIN 4102 and is covered by perforated plastic panels and glass fabric.

The standard **KRS** type with a packing thickness of approx. 100 mm is the most cost effective silencer for effective sound insulation.

Two further sizes with smaller or larger packing thickness are available for special applications:

- KRS/60** with building restraints in terms of outside diameter, relatively low attenuation
- KRS/140** with building restraints in terms of length, relatively high attenuation (also at low frequencies)

SELECTION

The selection of the nominal size is based on the volumetric flow where a flow rate of approx. 12 m/s should not be exceeded.

The required insertion loss determines the length of the silencer. The values at 250 Hz are specified in the table overleaf. The pressure loss/length as a function of the nominal diameter can be read off from the diagram.

The PC program **sdb.exe** enables comprehensive and fast selection, including pricing. This program, which also includes splitter attenuators, is easy to use and is available free of charge from MIETZSCH.

OPERATING CONDITIONS

Permissible flow and ambient temperature:

PVC 40 °C
PPs 70 °C

Permissible overpressure: 3500 Pa

Permissible negative pressure:

PVC 1300 Pa
PPs 700 Pa

Although installation outdoors is possible, PVD ducted silencers should be protected from direct sunlight.

Ducted silencers are not suitable for systems with high levels of condensation. Splitter attenuators with film-sealed absorbers should be used for such applications.

Please consult the manufacturer for other operating conditions.

DIMENSIONS / SOUND INSULATION

Standard series KRS Packing thickness approx. 100 mm						KRS/60 (small series) Packing thickness approx. 60 mm						KRS/140 (large series) Packing thickness approx. 140 mm					
D _N mm	D _A mm	De (250 Hz) / dB				D _N mm	D _A mm	De (250 Hz) / dB				D _N mm	D _A mm	De (250 Hz) / dB			
		Length L / mm						Length L / mm						Length L / mm			
		500	1000	1500	2000			500	1000	1500	2000			500	1000	1500	2000
110	315	17	33	-	-	110	250	9	19	28	38	110	355	21	43	50	50
125	355	17	33	-	-	125	280	9	19	28	38	125	400	21	42	50	50
140	355	13	26	39	-	140	280	7	15	22	29	140	400	17	34	50	50
160	400	13	26	39	-	160	315	7	15	22	30	160	450	17	34	50	50
180	400	11	21	32	42	180	315	6	11	17	23	180	450	14	27	41	50
200	450	11	22	33	44	200	355	6	13	19	25	200	500	14	28	42	50
225	450	9	18	27	36	225	355	5	9	14	19	225	500	11	23	34	45
250	500	10	19	29	38	250	400	5	11	17	21	250	560	12	24	36	48
280	500	8	15	23	30	280	400	-	8	12	16	280	560	10	20	30	40
315	560	8	16	24	32	315	450	-	9	13	18	315	630	10	19	29	38
355	560	7	13	20	26	355	450	-	6	9	12	355	630	8	17	25	34
400	630	7	14	21	28	400	500	-	6	9	13	400	700	8	15	23	30
450	700	7	13	20	26	450	560	-	7	11	14	450	750	-	-	-	-
500	750	6	12	18	24	500	630	-	8	13	17	500	800	-	-	-	-

PRESSURE LOSS

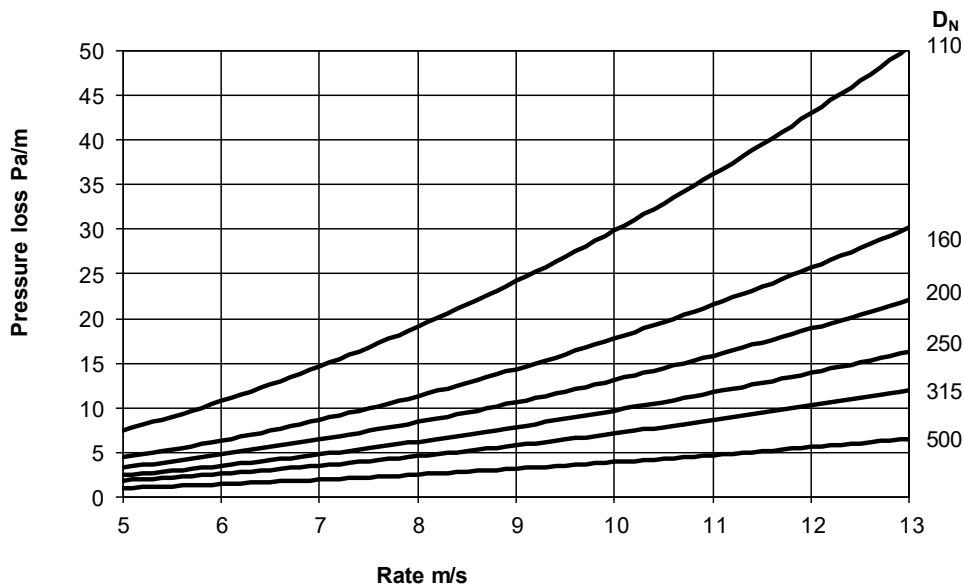

DESIGNATION

Example: Standard plastic ducted silencer (packing thickness approx. 100 mm)
Diameter 250 mm, length 1500 mm, material PPs

KRS 250 x 1500 PPs

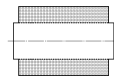

No. Qty.

Item

Unit price
EUR

Total price
EUR

Plastic ducted silencer

Mietzsch Lufttechnik - KRS Series

Absorption silencer made from plastic

Non-flammable sound insulation material in accordance with DIN 4102, covered with plastic perforated panels and glass fabric

Plastic housing, reinforced if necessary

Connections with coupling sleeve on both sides as standard

Material optionally PVC / PPs

KRS / - - - - X - - - -

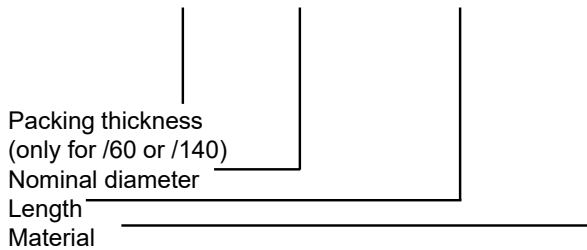

- Volumetric flow rate : _____ m³/h
- Inside diameter D_N : _____ mm
- Outside diameter D_a : _____ mm
- Length L : _____ mm
- Flow rate c : _____ m/s
- Pressure loss : _____ Pa
- Attenuation D_e at 250Hz : _____ dB
- Weight : _____ kg
- Temperature of flow medium : _____ °C

Flow medium/intended use:

Octave attenuation:

Octave attenuation D _e / dB							
63	125	250	500	1000	2000	4000	8000

Accessories and special equipment

- ◆ Welded flange on both sides; no holes or hole pattern 1 / hole pattern 2
- ◆ Miscellaneous

Plastic ducted silencer with core

KRS-K Series

Technical design

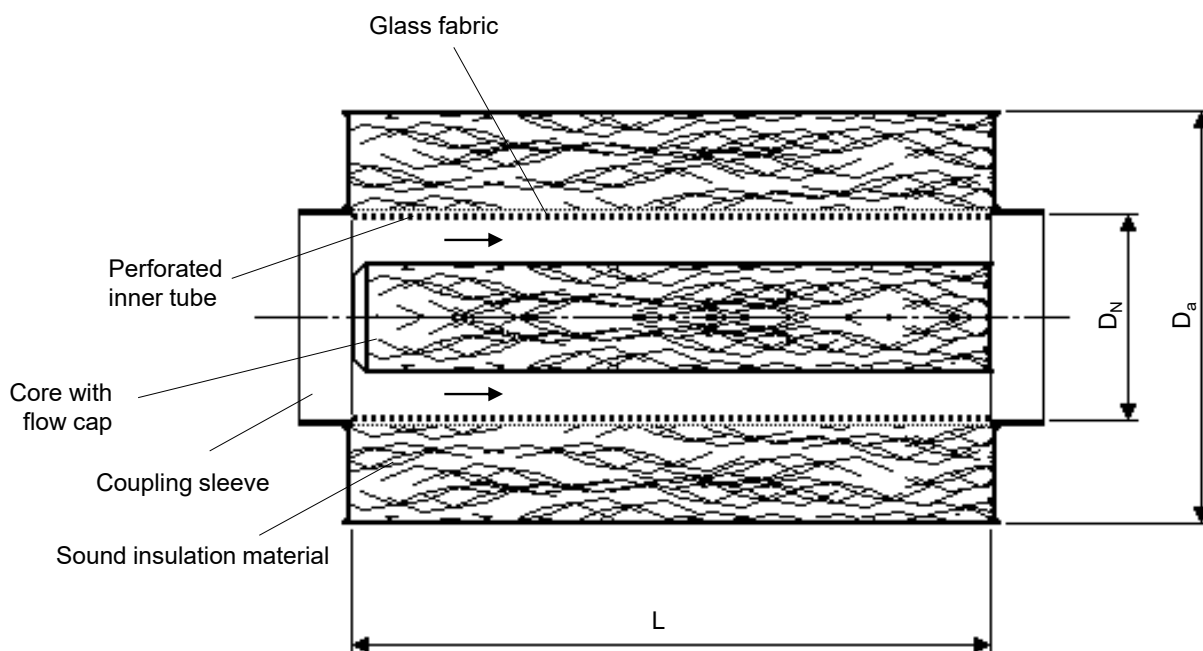

APPLICATION

The basic design and scope of application of the KRS-K series ducted silencers with core correspond to those of the KRS series ducted silencers (without core). It is additionally equipped with a welded central core with flow cap.

As the attenuation of ducted silencers without a core diminishes considerably with increasing diameter, especially in the high octaves (limiting effect), their suitability should be carefully assessed as from $D = 500$ mm (e.g. with a detailed sound insulation calculation through the octaves).

The additional core compensates for this disadvantage at high frequencies. This however means that pressure losses also increase at the same time.

Nevertheless, this silencer type often represents an effective alternative to splitter attenuators with a rectangular cross section.

The PC program **sdb.exe** enables comprehensive and fast selection, including pricing.

SELECTION / MAIN DIMENSIONS

DN	Da	L	63	125	250	500	1k	2k	4k	8k
500	720	500	2	3	7	12	19	20	13	9
		1000	2	5	12	23	34	35	21	12
		1500	3	7	17	33	45	45	28	14
560	780	500	2	3	7	13	17	18	14	8
		1000	2	5	11	22	31	32	22	10
		1500	3	7	16	32	44	45	30	12
630	850	500	2	3	6	12	16	17	12	7
		1000	2	4	11	21	28	29	17	9
		1500	3	6	15	30	40	41	23	10
710	930	500	1	3	6	11	15	16	10	7
		1000	2	4	10	19	25	26	14	8
		1500	2	6	14	27	36	37	18	9
800	1020	500	1	2	6	10	13	13	9	7
		1000	2	4	9	18	23	21	11	7
		1500	2	5	13	25	32	29	14	8
900	1120	500	1	2	5	10	13	11	8	6
		1000	2	4	8	17	22	16	10	7
		1500	2	5	12	24	30	22	12	7
1000	1220	500	1	3	5	10	13	10	7	6
		1000	2	4	8	17	20	13	9	7
		1500	2	6	11	23	27	17	10	7

Pressure loss guide

The pressure loss is within the area of the two limit curves. Calculate the loss exactly with the silencer calculation program sdb.exe.

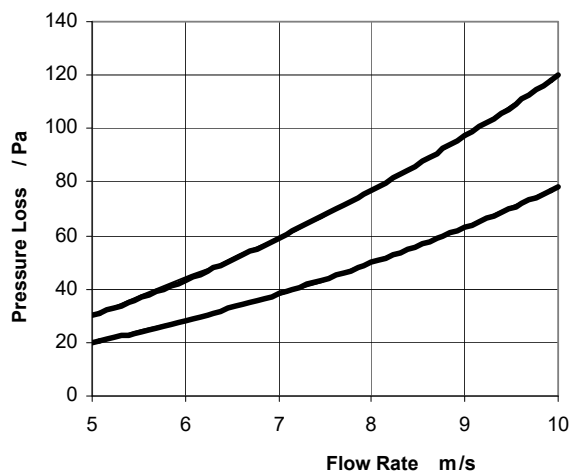

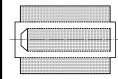

No.	Qty.	Item		Unit price EUR	Total price EUR
-----	------	------	--	-------------------	--------------------

Plastic ducted silencer with core

Mietzsch Lufttechnik - KRS-K Series

Absorption silencer made from plastic

Sound-absorbing core with flow cap

Non-flammable sound insulation material in accordance with DIN 4102, covered with plastic perforated panels and glass fabric

Plastic housing, reinforced if necessary

Connections with coupling sleeve on both sides as standard

Material optionally PVC / PPs

KRS-K - _ _ _ x _ _ _ - _ _ _

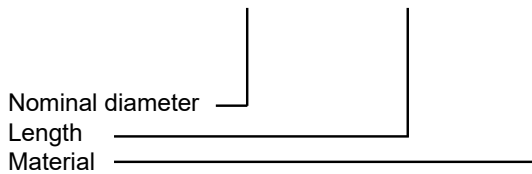

Volumetric flow rate	:	_____	m ³ /h
Inside diameter D _N	:	_____	mm
Outside diameter D _a	:	_____	mm
Length L	:	_____	mm
Flow rate c	:	_____	m/s
Pressure loss	:	_____	Pa
Attenuation D _e at 250Hz	:	_____	dB
Weight	:	_____	kg
Temperature of flow medium	:	_____	°C

Flow medium/intended use:

Octave attenuation:

Octave attenuation D _e / dB							
63	125	250	500	1000	2000	4000	8000

Accessories and special equipment

- ◆ Welded flange on both sides; no holes or hole pattern 1 / hole pattern 2
- ◆ Miscellaneous

Plastic splitter attenuator

Series KKS

Technical design

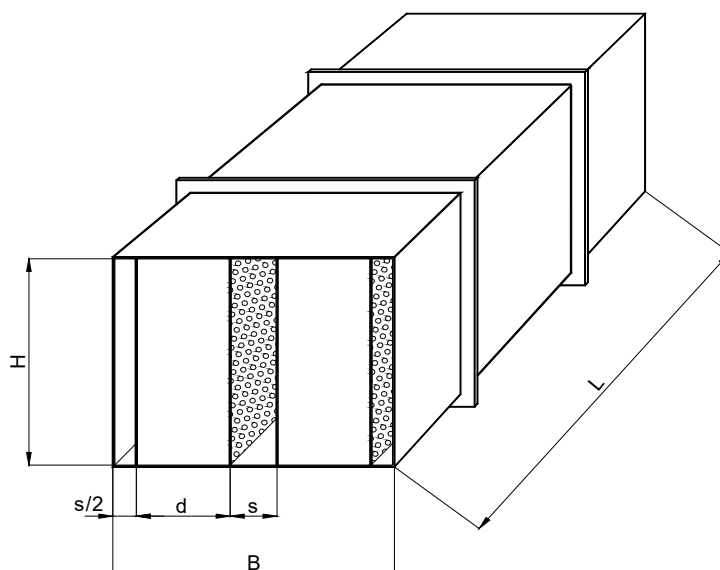

APPLICATION

The KKS series plastic splitter attenuators were specifically developed for efficient sound insulation in air conditioning and ventilation systems. Thanks to their outstanding resistance to chemicals, they are particularly suitable for applications involving moist or aggressive gases and vapours.

The absorber material is completely sealed in film to prevent chemical decomposition and fouling of the sound insulation material. The film also prevents the accumulation of bacteria, thus making the attenuators particularly suitable for use in hygiene applications.

TYPE SERIES and DESIGN

The splitter attenuators consists of a $W \times H \times L$ plastic duct with fixed baffles. The connection ends on both sides are smooth. Welded frames with or without holes are optionally available.

The absorber material is non-flammable in accordance with DIN 4102, sealed in sound-permeable PE film and covered by perforated plastic panels. To reduce pressure loss, the baffle is equipped as standard with a flow cap. The basic body is optionally made from PVC or PPs (other materials available on request).

2 different baffle thicknesses d and different gap widths s result in 4 basic types:

Type	d /mm	s /mm
KKS 200	200	100
KKS 240	240	75
KKS 240	240	160
KKS 240	240	260

The following main dimensions of the splitter attenuator are possible, where the width of the attenuator can only be whole number multiples of the grid dimension ($d + s$):

Width W : 300, 315, 400, 500, 600, 630, 800, 900, 945, 1000, 1200, 1260, 1500, 1600 mm
Height H : 200, 250, 315, 400, 500, 630, 700, 800, 900, 1000 mm (preferred dimensions)
Length L : 1000, 1500, 2000 mm

Thanks to this comprehensive range of dimensions, an optimum splitter attenuator can be selected for virtually any application.

If larger dimensions are required, special designs or split versions are possible on request. In addition, special versions can be created using computer-aided design.

Matching adapters and adapter ducts are optionally available.

OPERATING CONDITIONS

Permissible flow and ambient temperature: PVC 40 °C
PPs 70 °C

The materials used provide good **resistance** to many chemicals. Nevertheless, even plastic materials are susceptible to attack by certain substances.

In order to select the most suitable material, the intended use of the fan and the type of flow medium must always be quoted for queries or when placing an order.

Outdoor installation is possible. Please consult the manufacturer for other operating conditions.

SELECTION

The following criteria must be taken into account in terms of the acoustic design of the splitter attenuator:

- ◆ Required insertion loss D_e at 250 Hz
- ◆ Volumetric flow rate
- ◆ Permissible pressure loss
- ◆ Space requirements W/H/L
- ◆ Price

The following marginal conditions must also be observed:

- ◆ Narrow gaps result in high insertion loss but also high pressure loss.
- ◆ The flow rate through the gap should be between 6 and 12 m/s to ensure pressure loss and inherent noise remain low.
- ◆ The height H should not be too small ($H > 3 \cdot s$ where possible) otherwise diminished attenuation must be taken into account.

In most cases the calculation at 250 Hz is sufficient for the project planning of ventilation systems as this octave band generally defines the overall level. The required attenuator size can be determined in two steps with the aid of the selection diagrams A, B, C and D.

- ◆ Selection of basic type (baffle thickness and gap width) with the tables for octave attenuation. The required attenuation at 250 Hz and the constructional requirements in terms of the length must be taken into account.
- ◆ Based on the volumetric flow, the width and height are determined from the diagram. The constructional requirements must be taken into account.
The diagrams apply only for one flow rate, at which an attenuator has a pressure loss of 50 Pa.
If the height is selected smaller (or greater) than the setpoint, the flow rate and thus also the pressure loss will increase (or decrease) accordingly.

The requirement criteria can normally be met with different sized splitter attenuators. Several variants should always be calculated and compared.

The PC program **sdb.exe** enables comprehensive and fast selection, including pricing. This program, which also includes ducted silencers, is easy to use and is available free of charge from MIETZSCH.

Selection example

A splitter attenuator with the following specifications is required:

Attenuation at 250 Hz 20 dB
Volumetric flow rate 8000 m³/h
Dimensions maximum length 1500 mm, square cross section where possible

Selection based on attenuation (see arrows in the octave attenuation tables)

Variant 1 Selection diagram A: KKS200 $s = 100$ mm $L = 1000$ mm $D_e = 20$ dB
Variant 2 Selection diagram C: KKS240 $s = 160$ mm $L = 1500$ mm $D_e = 22$ dB
Variant 3 Selection diagram D: KKS240 $s = 260$ mm $L = 2000$ mm $D_e = 20$ dB
--> Variant 3 cannot be used due to the excessive overall length.

Determining width and height (see arrows in diagrams A and C)

Variant 1 Selection diagram A: $B = 900$ mm $H = 900$ mm (selected)
Variant 2 Selection diagram C: $B = 800$ mm $H = 700$ mm

Result and designation for the two possible variants

Variant 1 KKS200 900 x 900 x 1000 with $D_e = 20$ dB pressure loss < 50 Pa
Variant 2 KKS240 800 x 700 x 1500 with $D_e = 22$ dB pressure loss = 58 Pa

INSTALLATION

Installation position:

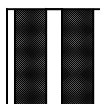

The baffles must be arranged vertically when installing the splitter attenuator!

Plastic splitter attenuator

Series KKS

Technical design



Selection diagram A

KKS200

Baffle thickness: 200 mm
 Gap width: 100 mm
 Flow rate through gap: 8.7 m/s (→ pressure loss 50 Pa at attenuator length of 1000 mm)

Baffle arrangement

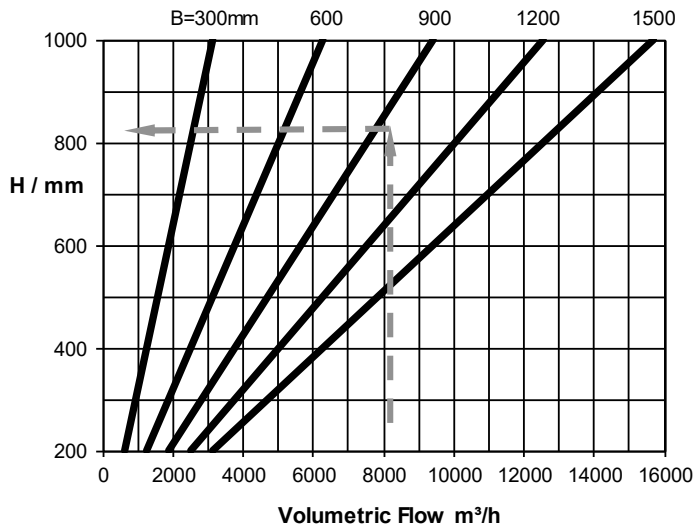
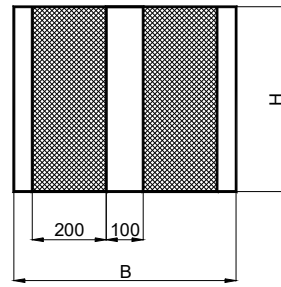

Length L mm	Octave attenuation D_e / dB								Pressure Loss Pa
	63	125	250	500	1000	2000	4000	8000	
1000	3	9	20	29	37	29	20	16	50
1500	4	11	25	35	44	38	25	20	55
2000	5	14	30	39	50	46	31	24	60

Variant 1

Selection diagram B

KKS240

Baffle thickness: 240 mm
 Gap width: 75 mm
 Flow rate through gap: 6.4 m/s (→ pressure loss 50 Pa at attenuator length of 1000 mm)

Baffle arrangement

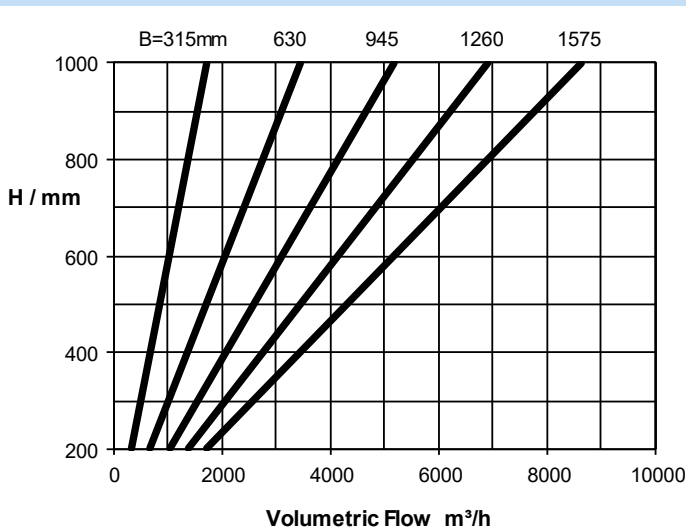
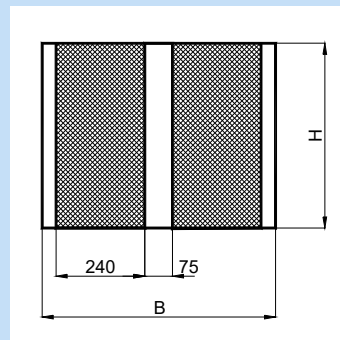

Length L mm	Octave attenuation D_e / dB								Pressure Loss Pa
	63	125	250	500	1000	2000	4000	8000	
1000	3	13	25	31	39	30	20	16	50
1500	4	15	28	34	45	38	25	20	55
2000	5	16	32	38	50	46	31	24	60

Plastic splitter attenuator

Series KKS

Technical design

Selection diagram C

KKS240

Baffle thickness: 240 mm
 Gap width: 160 mm
 Flow rate through gap: 9.9 m/s (→ pressure loss 50 Pa at attenuator length of 1000 mm)

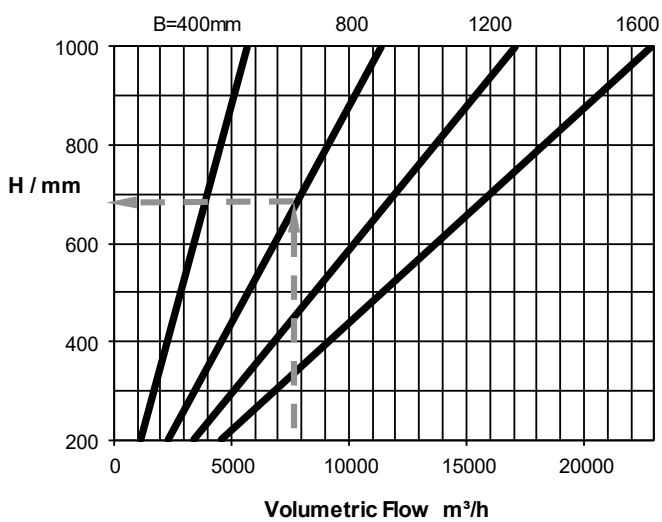

Baffle arrangement

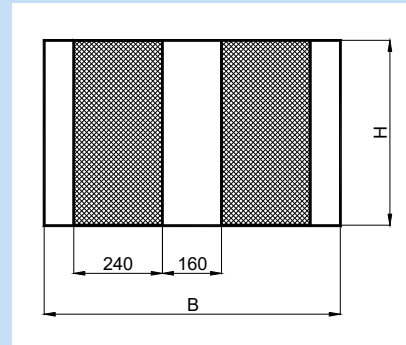

Length L mm	Octave attenuation De / dB								Pressure Loss Pa
	63	125	250	500	1000	2000	4000	8000	
1000	3	9	17	22	27	16	14	12	50
1500	4	13	22	29	34	21	17	15	58
2000	5	17	28	35	41	26	21	18	65

Variant 2

Selection diagram D

KKS240

Baffle thickness: 240 mm
 Gap width: 260 mm
 Flow rate through gap: 12.6 m/s (→ pressure loss 50 Pa at attenuator length of 1000 mm)

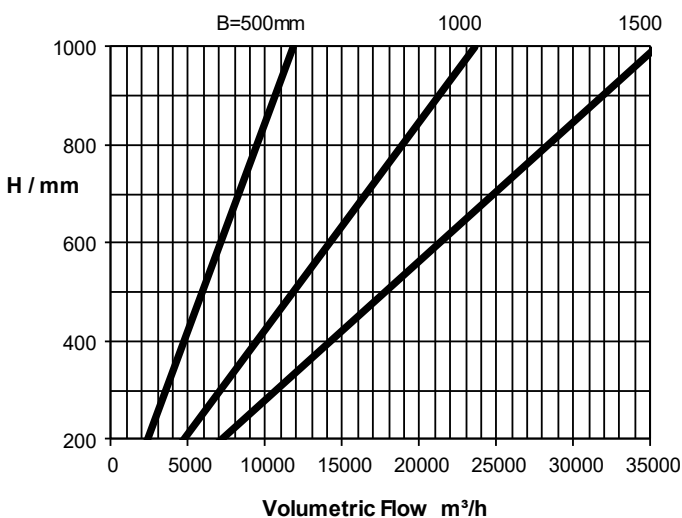

Baffle arrangement

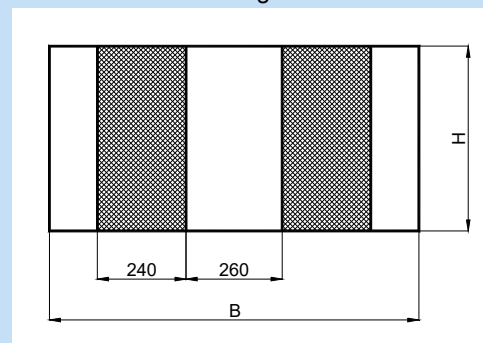

Length L mm	Octave attenuation De / dB								Pressure Loss Pa
	63	125	250	500	1000	2000	4000	8000	
1000	2	7	10	14	15	10	9	8	50
1500	3	10	15	19	20	13	11	10	59
2000	3	13	20	24	25	16	13	11	69

Variant 3

No.	Qty.	Object		Unit price EUR	Total price EUR
-----	------	--------	--	----------------	-----------------

Plastic splitter attenuator

Mietzsch Lufttechnik - KKS Series

Corrosion resistant absorption attenuator with fixed baffles.

Baffles made of sound insulation material (non-flammable as per DIN 4102) sealed in film and covered with plastic perforated panels, with flow cap.

Baffle thickness optionally 200/240 mm

Plastic housing, reinforced if necessary
Smooth connections on both sides as standard.

Material optionally PVC / PPs

KKS - - - - - **X** - - - - - **X** - - - - -

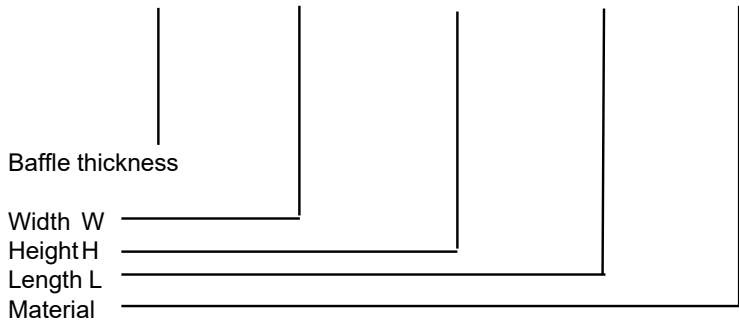

- Volumetric flow rate : _____ m³/h
- Width W : _____ mm
- Height H : _____ mm
- Length L : _____ mm
- Flow rate through gap c : _____ m/s
- Pressure loss : _____ Pa
- Attenuation D_e at 250 Hz : _____ dB
- Weight : _____ kg

Temperature of flow medium : _____ °C

Flow medium/intended use:

Octave attenuation:

Octave attenuation D _e / dB							
63	125	250	500	1000	2000	4000	8000

Accessories and special equipment

- ◆ Welded frame on both sides; no holes or hole pattern 1 / hole pattern 2
- ◆ (Duct) adapter, symmetrically, with coupling sleeves
- ◆ Adapter duct, symmetrical, with coupling sleeves
- ◆ Miscellaneous

Soundproofing enclosure with self-ventilation for radial fan VRE

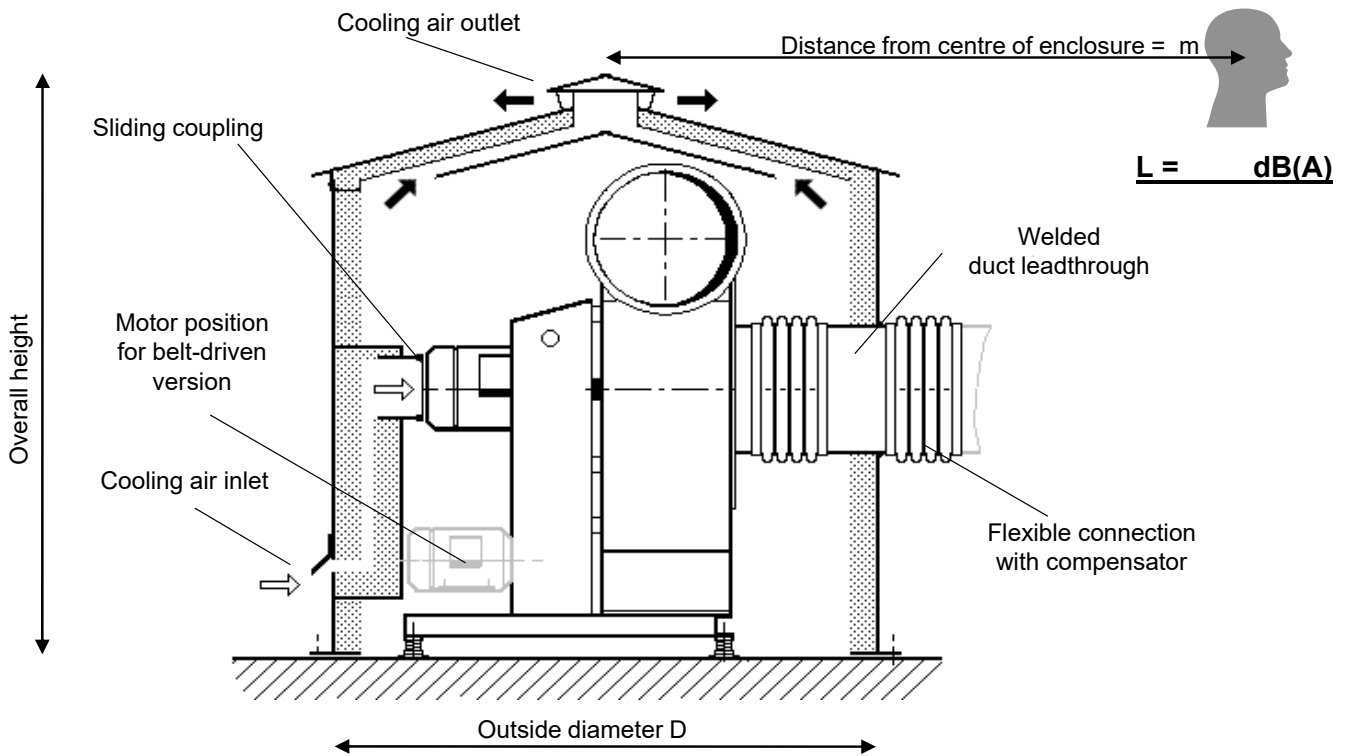

Fan type:

VRE _____ / _____ (housing position 0° or 180°)

Sound pressure level at a distance of 3 m $L_{3m} = \dots\dots\dots$ dB(A)

Motor: $\dots\dots\dots$ kW

Technical data:

Insulation loss D_e at 250 Hz: $\dots\dots\dots$ dB

Sound pressure level at reference point with clear sound radiation --> see above!

Design in accordance with DIN EN ISO 15667 recommendations.

Construction: Cylindrical basic body made from plastic panels, offering outstanding corrosion resistance

Absorber made from 50 mm non-flammable mineral wool, laminated with glass fibre mat and covered with perforated panels

Basic body 1-piece / basic body consisting of two parts screwed together

Detachable conical roof with integrated cooling air outlet

Access to fan: Via the detachable roof, secured with quick-release latches/from side through integrated door

Wall material: PVC (RAL 7011) / PPs (RAL 7036) / PE (black)

Installation of even ground / installation of steel brackets (with additional base)

Isolation of structure-borne noise with high grade foam material (included in scope of delivery)

Place of installation: Indoor / outdoor Max. ambient temperature: $\dots\dots\dots$ °C

Ventilation by cooling fan of motor. Cooling air routed via integrated silencers.

With cable leadthrough.

Dimensions: Round version D: approx. $\dots\dots\dots$ mm Height: approx. $\dots\dots\dots$ mm

Weight: approx. $\dots\dots\dots$ kg

Terms and conditions of delivery:

Price for shipping : $\dots\dots\dots$ EUR (net ex factory)

Delivery time: $\dots\dots\dots$ weeks (after clarification of all details)

Soundproofing enclosure with self-ventilation für duct fan VRK

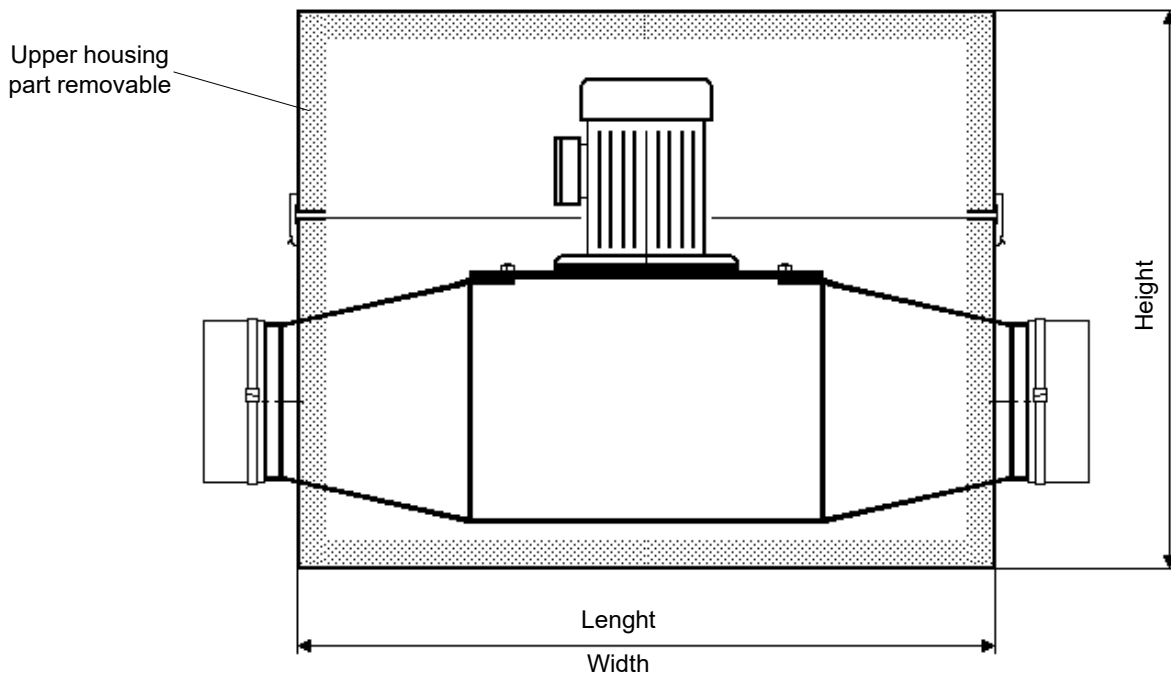

Fan type :

VRK ___ / 731 W ____

Sound pressure level at a distance of 3 m

$L_{3m} = \dots\dots\dots$ dB(A)

Motor: kW

Technische Angaben :

Insulation loss D_e at 250 Hz: 15 dB

Design in accordance with DIN EN ISO 15667 recommendations.

Construction: Housing made from plastic panels, offering outstanding corrosion resistance

Absorber made from 50 mm non-flammable mineral wool, laminated with glass fibre mat and covered with perforated panels

Housing consisting of two parts screwed together

Detachable roof with integrated cooling air outlet

Access to fan: Via the detachable roof, secured with quick-release latches

Wall material: PVC (RAL 7011) / PPs (RAL 7036) / PE (black)

Installation on steel bracket (with additional base)

Aufstellungsort: Innenaufstellung max. Umgebungstemperatur: °C

Ventilation via motor cooling fan. Cooling air routed via integrated silencer.

With cable leadthrough.

Dimensions: Length / Width / Hight approx. x x mm

Weight : approx. kg

Terms and conditions of delivery:

Price for shipping : EUR (net ex factory)

Delivery time: weeks (after clarification of all details)

Soundproofing enclosure for roof fan VRR

Version examples/pressure loss

Example 1

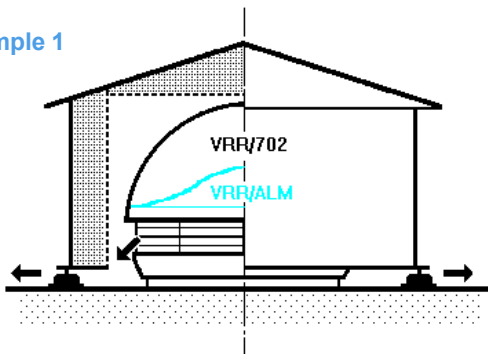

Soundproofing enclosure for flat roof

Fan type: VRR/ALM (with external rotor motor)
VRR/702 (with standard motor)

Exhaust air outlet horizontal at bottom of enclosure
Suitable only for relatively clean exhaust air
Attenuation, outlet side: 10 dB(A)

Example 2

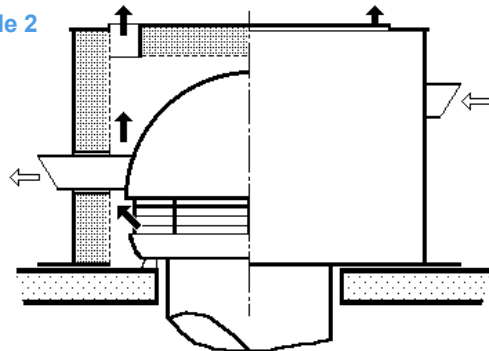

Soundproofing enclosure for flat roof

Fan type: VRR/702 (with standard motor)

Motor separated from exhaust air flow and ventilated
Exhaust air outlet vertical
Suitable for aggressive laboratory waste air
Attenuation, outlet side: 10 dB(A)

Example 3

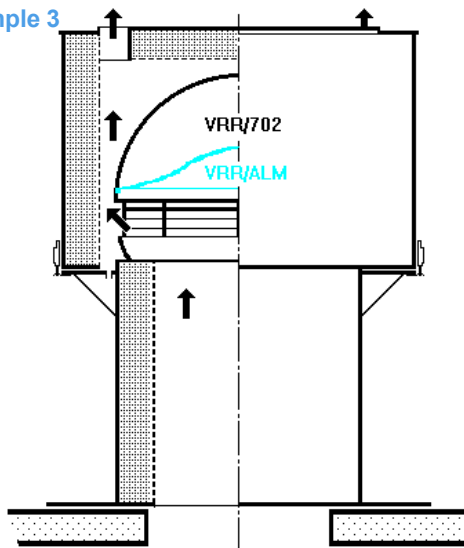

Sound insulation base and soundproofing enclosure

Fan type: VRR/ALM (with external rotor motor)
VRR/702 (with standard motor)

Exhaust air outlet vertical
Suitable only for relatively clean exhaust air
Attenuation, outlet side: 10 dB(A)
Attenuation, inlet side: 8 dB(A)

Example 4

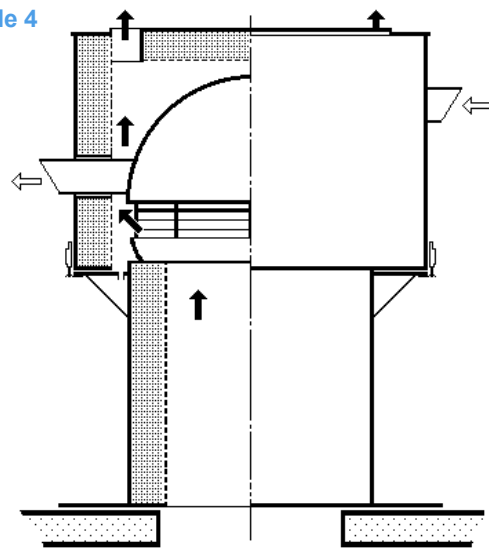

Sound insulation base and soundproofing enclosure

Fan type: VRR/702 (with standard motor)

Exhaust air outlet vertical
Suitable for aggressive laboratory waste air
Attenuation, outlet side: 10 dB(A)
Attenuation, inlet side: 8 dB(A)

Pressure loss of soundproofing enclosure

The maximum pressure loss of the sound insulation base is 20 Pa.

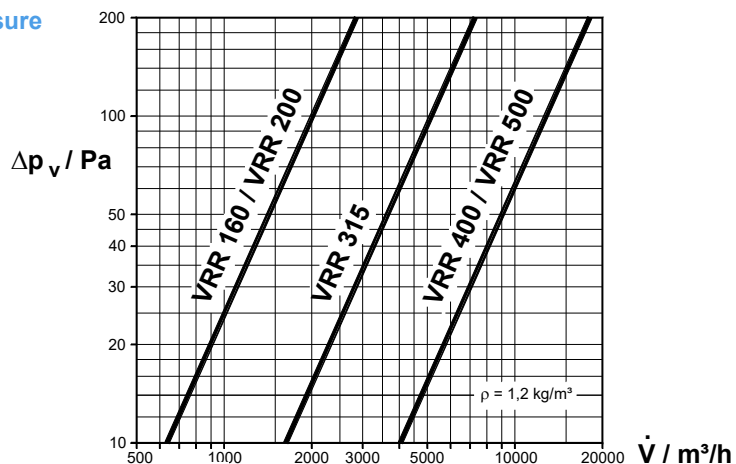

Our program of products and services

Roof fans

of all-plastic design, horizontally or vertically blowing out with many assembly accessories

Radial fans

of thermoplastic material and FRP, direct and belt driven up to about 150 000 m³/h and 6 500 Pa

Special fans

duct fans, built-in devices, mobile radial fans, Venturi injectors

Explosion-proof fans

according to ATEX for zone 1 and zone 2

AIR technology systems and components

pipes, ducts, fittings, flaps, gas-tight shutoff flaps, exhaust air hoods, deflector hoods, suction hoods and many more of plastic material, complete air technology systems for industry and craft, air cleaning plants, laboratory and process exhaust systems

Central ventilation systems

in housing construction, special-purpose fans, exhaust elements, controlling and regulating devices

Noise protection

rectangular and cylindrical sound attenuators, silencing casings in corrosion-proof design

Exhaust gas cleaning

droplet eliminators and moisteners, gas scrubbers for separation of gaseous dangerous substances, dust filter

Heat exchangers

for heat recovery from moist and aggressive exhaust air

Tanks

of thermoplastic material for liquids endangering water, according to water resources regulations

Controlling and regulating elements and systems

switches, motor protection devices, speed controllers, frequency inverter, fan controls, flow supervision

Special designs

devices, linings, special components etc. of plastic material

Engineering performances

planning, calculation, and design, ventilation measurement on standardized test stands, low and high temperature test in company-own climatic test chambers

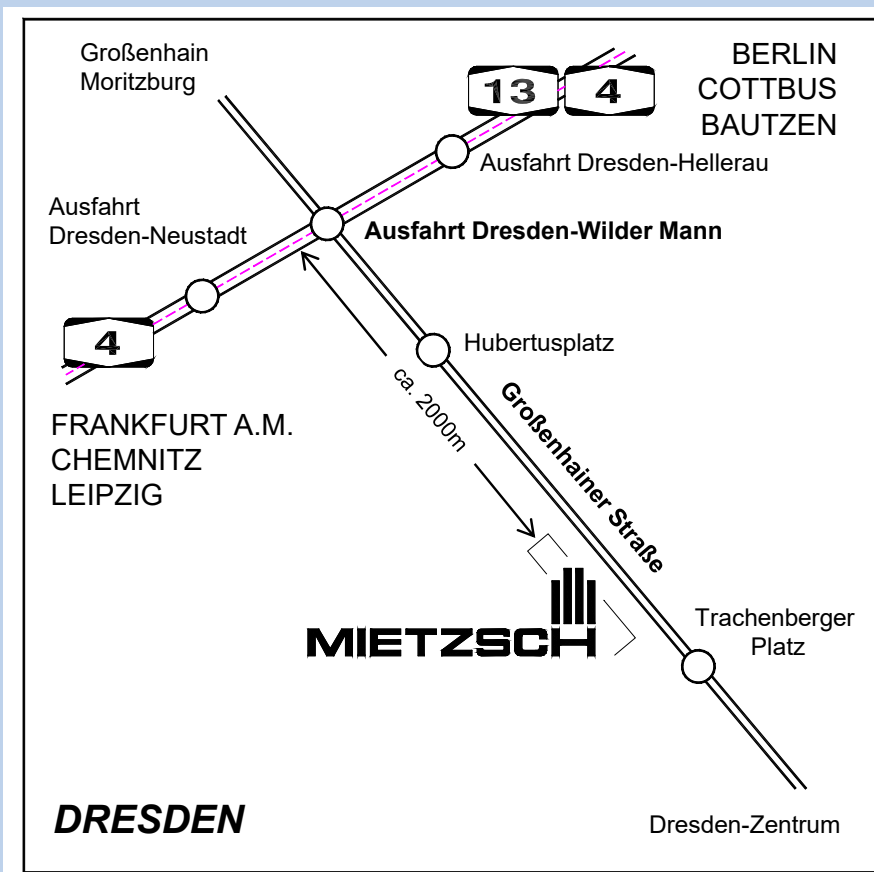

MIETZSCH

GmbH Lufttechnik Dresden

Großenhainer Straße 137
DE-01129 Dresde

Telefon: +49 (0351) 8433 0
FAX: +49 (0351) 8433 160
E-mail: mietzsch@mietzsch.de
Internet: <http://www.mietzsch.de>